

Features

- Operating voltage: 2.4V~12V
- Low power and high noise immunity CMOS technology
- Low standby current
- Three words transmission
- Built-in oscillator needs only 5% resistor
- Easy interface with an RF or infrared transmission media
- Minimal external components

Applications

- Burglar alarm system
- Smoke and fire alarm system
- Garage door controllers
- Car door controllers
- Car alarm system
- Security system
- Cordless telephones
- Other remote control systems

General Description

The 3¹⁸ encoders are a series of CMOS LSIs for remote control system applications. They are capable of encoding 18 bits of information which consists of N address bits and 18-N data bits. Each address/data input is externally trinary programmable if bonded out. It is otherwise set floating internally. Various packages of the 3¹⁸ encoders offer flexible combinations of

programmable address/data to meet various application needs. The programmable address/data is transmitted together with the header bits via an RF or an infrared transmission medium upon receipt of a trigger signal. The capability to select a TE trigger type or a DATA trigger type further enhances the application flexibility of the 3¹⁸ series of encoders.

Selection Table

Function Part No.	Address No.	Address/ Data No.	Data No.	Dummy Code No.	Oscillator	Trigger	Package
HT600	9	5	0	4	RC oscillator	TE	20 DIP/20 SOP
HT640	10	8	0	0	RC oscillator	TE	24 SOP/24 SDIP
HT680	8	4	0	6	RC oscillator	TE	18 DIP
HT6187	9	0	3	6	RC oscillator	D12,D14,D15	18 DIP/20 SOP
HT6207	10	0	4	4	RC oscillator	D12~D15	20 DIP/20 SOP
HT6247	12	0	6	0	RC oscillator	D12~D17	24 SOP/24 SDIP

Note: Address/Data represents addressable pins or data according to the decoder requirements.

Block Diagram

TE trigger

HT600/HT640/HT680

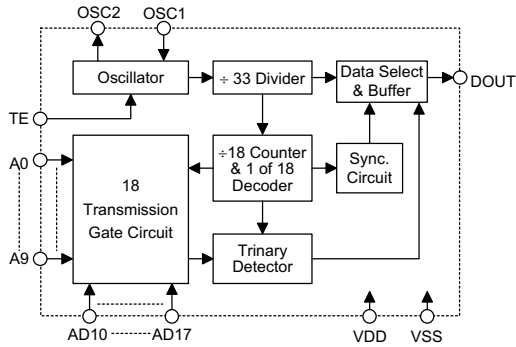

DATA trigger

HT6187/HT6207/HT6247

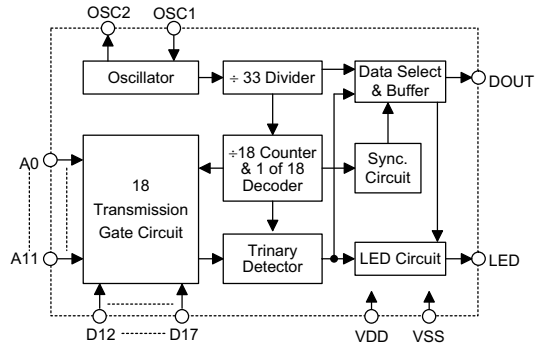

Note: The address/data pins are available in various combinations.

Pin Assignment

TE trigger type

**9-Address
5-Address/Data**

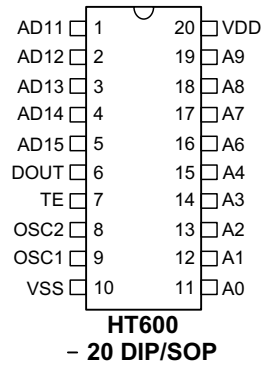

**8-Address
4-Address/Data**

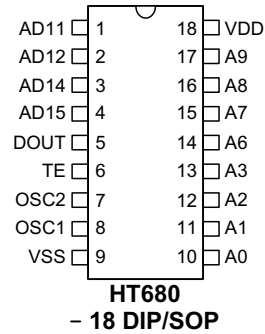

**10-Address
8-Address/Data**

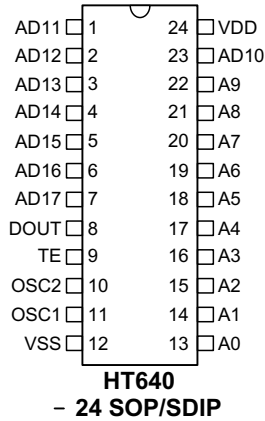

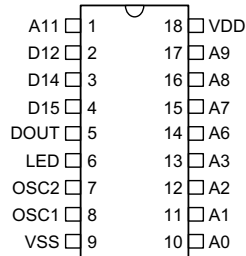
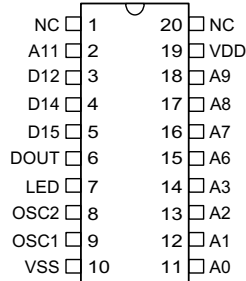
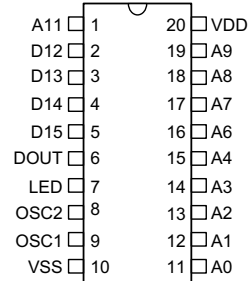
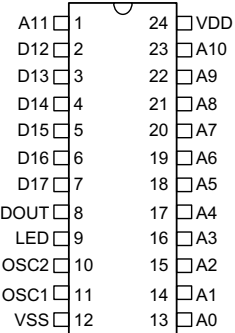
DATA trigger type
**9-Address
3-Data**

**HT6187
- 18 DIP**
**9-Address
3-Data**

**HT6187
- 20 SOP**
**10-Address
4-Data**

**HT6207
- 20 DIP/SOP**
**12-Address
6-Data**

**HT6247
- 24 SOP/SDIP**
Pin Description

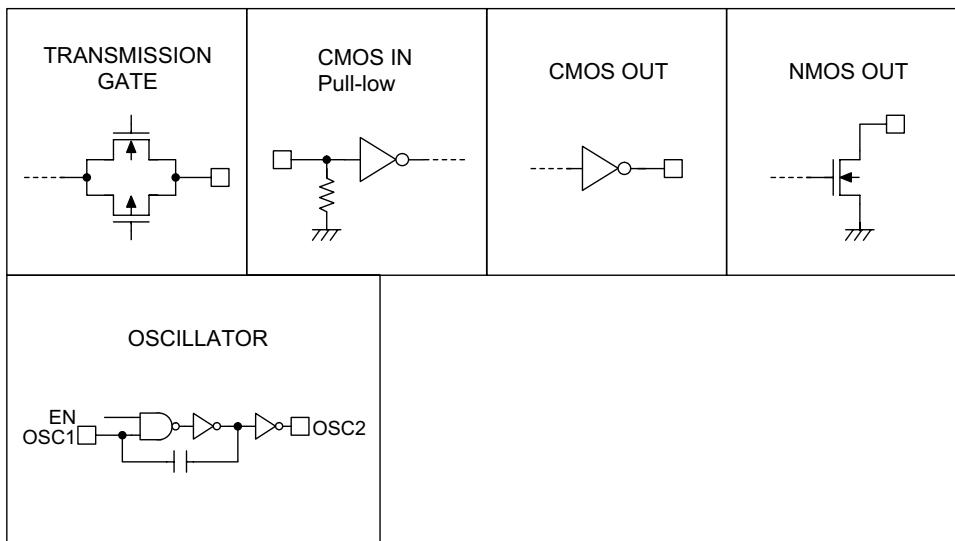
Pin Name	I/O	Internal Connection	Description
A0~A11	I	TRANSMISSION GATE	Input pins for address A0~A11 setting They can be externally set to VDD, VSS, or left open.
AD10~AD17	I	TRANSMISSION GATE	Input pins for address/data (AD10~AD17) setting They can be externally set to VDD, VSS, or left open.
D12~D17	I	CMOS IN Pull-low	Input pins for data (D12~D17) setting and transmission enable (active high) They can be externally set to VDD or left open (see Note).
DOUT	O	CMOS OUT	Encoder data serial transmission output
LED	O	NMOS OUT	LED transmission enable indicator
TE	I	CMOS IN Pull-low	Transmission enable, active high (see Note).
OSC1	I	OSCILLATOR	Oscillator input pin
OSC2	O	OSCILLATOR	Oscillator output pin
VSS	I	—	Negative power supply (GND)
VDD	I	—	Positive power supply

Notes: D12~D17 are data input and transmission enable pins of the HT6187/HT6207/HT6247.

TE is the transmission enable pin of the HT600/HT640/HT680.

Approximate internal connection circuits



Absolute Maximum Ratings

Supply Voltage.....	-0.3V to 13V	Input Voltage	$V_{SS}-0.3$ to $V_{DD}+0.3V$
Storage Temperature.....	-50°C to 125°C	Operating Temperature	-20°C to 75°C

Note: These are stress ratings only. Stresses exceeding the range specified under "Absolute Maximum Ratings" may cause substantial damage to the device. Functional operation of this device at other conditions beyond those listed in the specification is not implied and prolonged exposure to extreme conditions may affect device reliability.

Electrical Characteristics

$T_a=25^\circ C$

Symbol	Parameter	Test Conditions		Min.	Typ.	Max.	Unit
		V_{DD}	Conditions				
V_{DD}	Operating Voltage	—	—	2.4	—	12	V
I_{STB}	Standby Current	3V	Oscillator stops	—	0.1	1	μA
		12V		—	2	4	μA
I_{DD}	Operating Current	5V	No load $f_{OSC}=100kHz$	—	250	500	μA
		12V		—	1200	2400	μA
I_{LED}	LED Sink Current	5V	$V_{LED}=0.5V$	1.5	3	—	mA
I_{DOUT}	Output Drive Current	5V	$V_{OH}=0.9V_{DD}$ (Source)	-0.6	-1.2	—	mA
		5V	$V_{OL}=0.1V_{DD}$ (Sink)	0.6	1.2	—	mA

Symbol	Parameter	Test Conditions		Min.	Typ.	Max.	Unit
		V _{DD}	Conditions				
V _{IH}	"H" Input Voltage	—	—	0.8V _{DD}	—	V _{DD}	V
V _{IL}	"L" Input Voltage	—	—	0	—	0.2V _{DD}	V
f _{OSC}	Oscillator Frequency	10V	R _{OSC} =330kΩ	—	100	—	kHz
R _{TE}	TE Pull-low Resistance	5V	V _{TE} =5V	—	1.5	3	MΩ
R _{DATA}	D12~D17 Pull-low Resistance	5V	V _{DATA} =5V	—	1.5	3	MΩ

Functional Description

Operation

The 3¹⁸ series of encoders begins a three-word transmission cycle upon receipt of a transmission enable (TE for the HT600/HT640/HT680 or D12~D17 for the HT6187/HT6207/HT6247, active high). This cycle will repeat itself as long as the transmission enable (TE or D12~D17) is held high. Once the transmission enable falls low, the encoder output completes its final cycle and then stops as shown below.

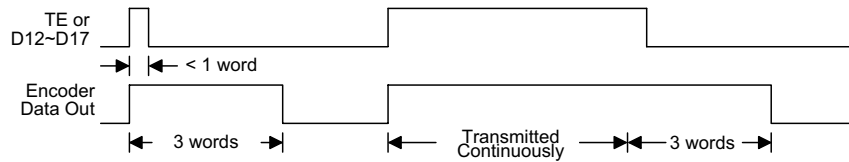

Transmission timing

Information word

An information word consists of 4 periods as shown:

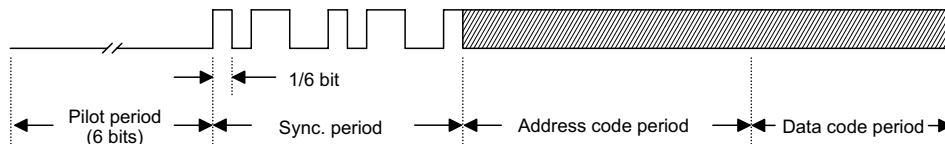

Composition of information

Address/data waveform

Each programmable address/data pin can be externally set to one of the following three logic states:

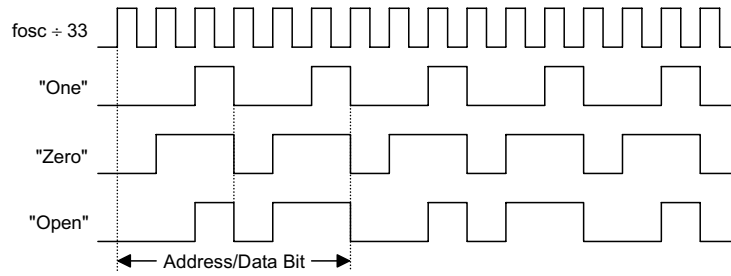

Address/Data bit waveform

The "Open" state data input is interpreted as logic low by the decoders since the decoder output only have two states.

Address/data programming (preset)

The status of each address/data pin can be individually preset to logic "high", "low", or "floating". If a transmission enable signal is applied, the encoder scans and transmits the status of the 18 bits of address/data serially in the order A0 to AD17 for the HT600/HT640/HT680 and A0 to D17 for the HT6187/HT6207/HT6247.

There are some packaging limitations. The 18-pin DIP HT680, for example, offers four external data bits and eight external address bits. The remaining unpackaged bits or dummy codes are treated as floating for A0~AD17 or as pull-low for D12~D17. During an information transmission these bits are still located in their original position. But if the trigger signal is not applied, the chip only consumes a standby current which is less than 1µA.

The address pins are usually preset to transmit data codes with particular security codes by the DIP switches or PCB wiring, while the data is selected using push buttons or electronic switches.

The following figure shows an application using the HT680:

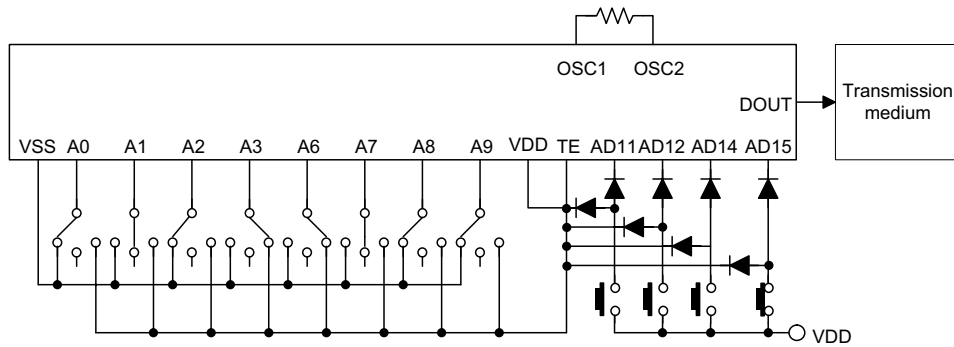

The transmitted information is as shown:

Pilot & Sync.	A0	A1	A2	A3	A4	A5	A6	A7	A8	A9	AD10	AD11
	0	Z	0	1	Z	Z	1	Z	0	0	Z	Z
—	AD12	AD13	AD14	AD15	AD16	AD17						
	Z	Z	Z	1	Z	Z						

Z: floating

Address/Data sequence

The following provides a table of address/data sequence for various models of the 3¹⁸ series encoders. A correct device should be selected according to the individual address and data requirements.

Part No.	Address/Data Bits											
	0~3	4	5	6~9	10	11	12	13	14	15	16	17
HT600	A0~A3	A4	—	A6~A9	—	AD11	AD12	AD13	AD14	AD15	—	—
HT640	A0~A3	A4	A5	A6~A9	AD10	AD11	AD12	AD13	AD14	AD15	AD16	AD17
HT680	A0~A3	—	—	A6~A9	—	AD11	AD12	—	AD14	AD15	—	—
HT6187	A0~A3	—	—	A6~A9	—	A11	D12	=	D14	D15	=	=
HT6207	A0~A3	A4	—	A6~A9	—	A11	D12	D13	D14	D15	=	=
HT6247	A0~A3	A4	A5	A6~A9	AD10	A11	D12	D13	D14	D15	D16	D17

Notes: "—" is a dummy code which is left "open" and not bonded out.

"=" is a dummy code which is set low and not bonded out.

Transmission enable

For the TE trigger type of encoders, transmission is enabled by applying a high signal to the TE pin. But for the Data trigger type of encoders, it is enabled by applying a high signal to one of the data pins D12~D17.

Flowchart

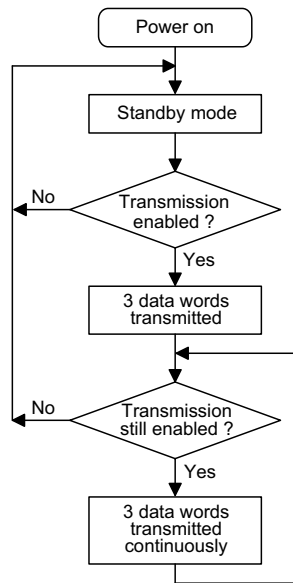

Notes: D12~D17 are transmission enables of the HT6187/HT6207/HT6247.

TE is the transmission enable of the HT600/HT640/HT680.

Oscillator frequency vs supply voltage

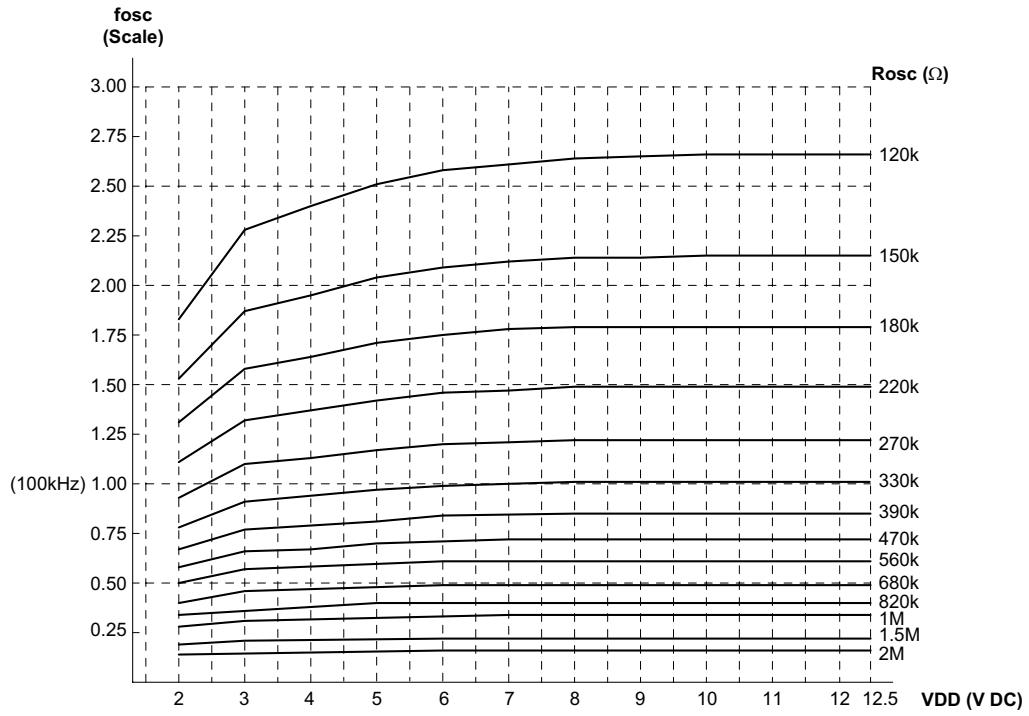

The recommended oscillator frequency is $f_{OSCD} \text{ (decoder)} \cong f_{OSCE} \text{ (encoder)}$.

Application Circuits

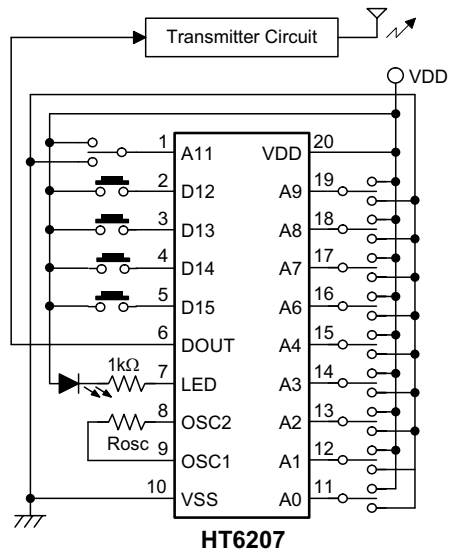
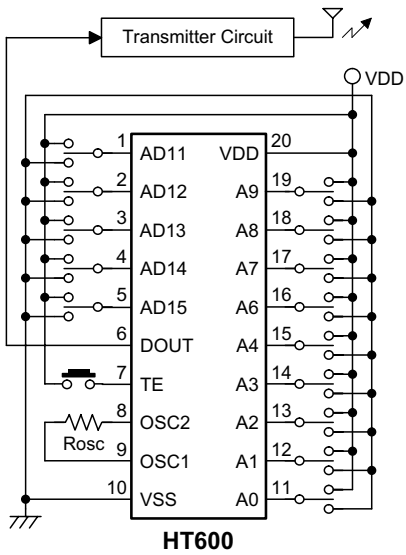
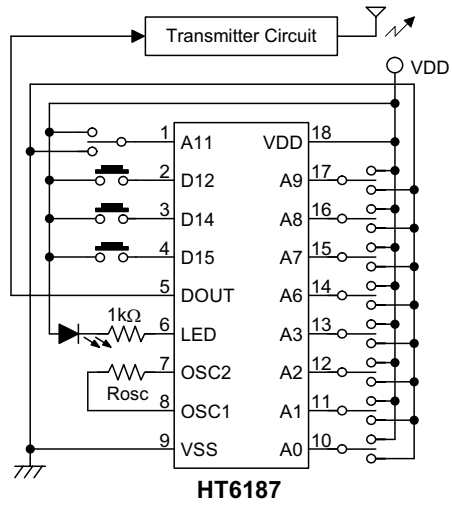
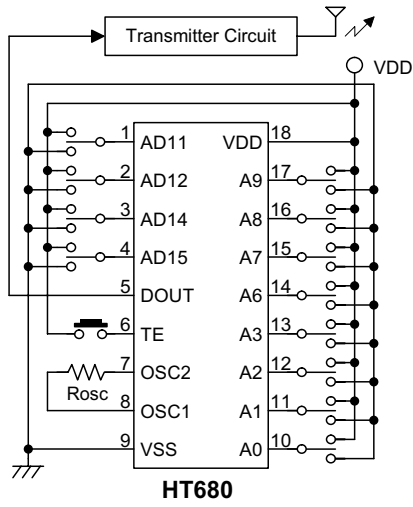

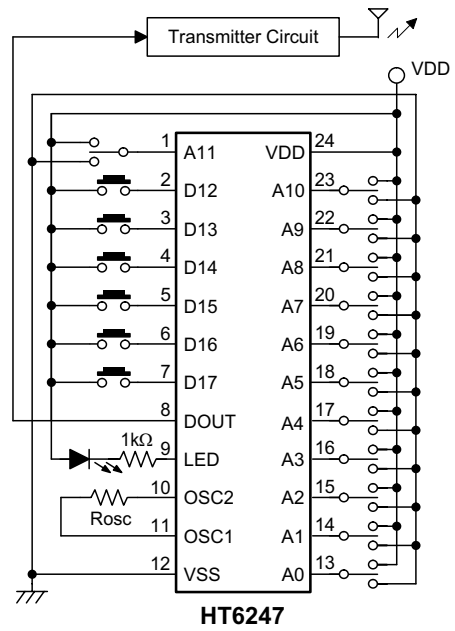
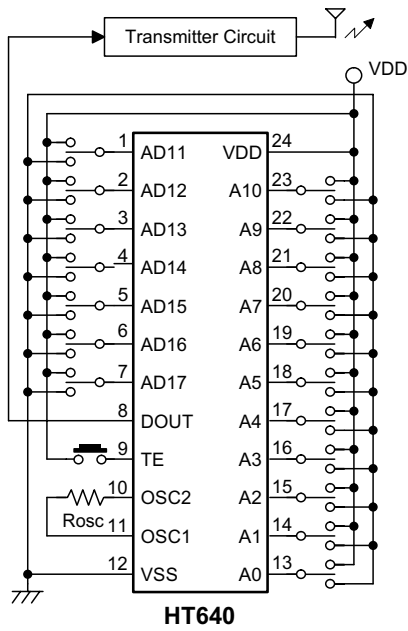

Notes: Typical infrared diode: EL-1L2 (KODENSHI CORP.)
 Typical RF transmitter: JR-220 (JUWA CORP.)
 TX-99 (MING MICROSYSTEM, U.S.A.)

Holtek Semiconductor Inc. (Headquarters)

No.3 Creation Rd. II, Science-based Industrial Park, Hsinchu, Taiwan, R.O.C.
Tel: 886-3-563-1999
Fax: 886-3-563-1189

Holtek Semiconductor Inc. (Taipei Office)

5F, No.576, Sec.7 Chung Hsiao E. Rd., Taipei, Taiwan, R.O.C.
Tel: 886-2-2782-9635
Fax: 886-2-2782-9636
Fax: 886-2-2782-7128 (International sales hotline)

Holtek Microelectronics Enterprises Ltd.

RM.711, Tower 2, Cheung Sha Wan Plaza, 833 Cheung Sha Wan Rd., Kowloon, Hong Kong
Tel: 852-2-745-8288
Fax: 852-2-742-8657

Copyright © 1999 by HOLTEK SEMICONDUCTOR INC.

The information appearing in this Data Sheet is believed to be accurate at the time of publication. However, Holtek assumes no responsibility arising from the use of the specifications described. The applications mentioned herein are used solely for the purpose of illustration and Holtek makes no warranty or representation that such applications will be suitable without further modification, nor recommends the use of its products for application that may present a risk to human life due to malfunction or otherwise. Holtek reserves the right to alter its products without prior notification. For the most up-to-date information, please visit our web site at <http://www.holtek.com.tw>.