

### Features

- Low power consumption
- Low voltage drop
- Low temperature coefficient
- High input voltage (up to 24V)
- Output voltage accuracy: tolerance  $\pm 3\%$
- TO-92, SOT-89 and SOT-25 package

### Applications

- Battery-powered equipment
- Communication equipment
- Audio/Video equipment

### General Description

The HT71XX-1 series is a set of three-terminal low power high voltage regulators implemented in CMOS technology. They allow input voltages as high as 24V. They are available with several fixed output voltages ranging from 3.0V to 5.0V. CMOS technology ensures low voltage drop and low quiescent current.

Although designed primarily as fixed voltage regulators, these devices can be used with external components to obtain variable voltages and currents.

### Selection Table

Part No.	Output Voltage	Tolerance	Package	Marking
HT7130-1	3.0V	$\pm 3\%$	TO-92 SOT-89 SOT-25	71XXA-1 (for TO-92) 71XX-1 (for SOT-89) 1XX1 (for SOT-25)
HT7133-1	3.3V	$\pm 3\%$		
HT7136-1	3.6V	$\pm 3\%$		
HT7144-1	4.4V	$\pm 3\%$		
HT7150-1	5.0V	$\pm 3\%$		

Note: "XX" stands for output voltages.

### Block Diagram

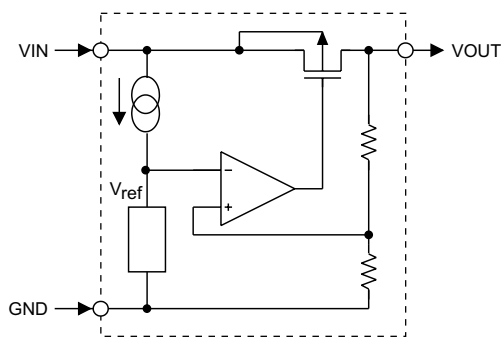

**Pin Assignment**

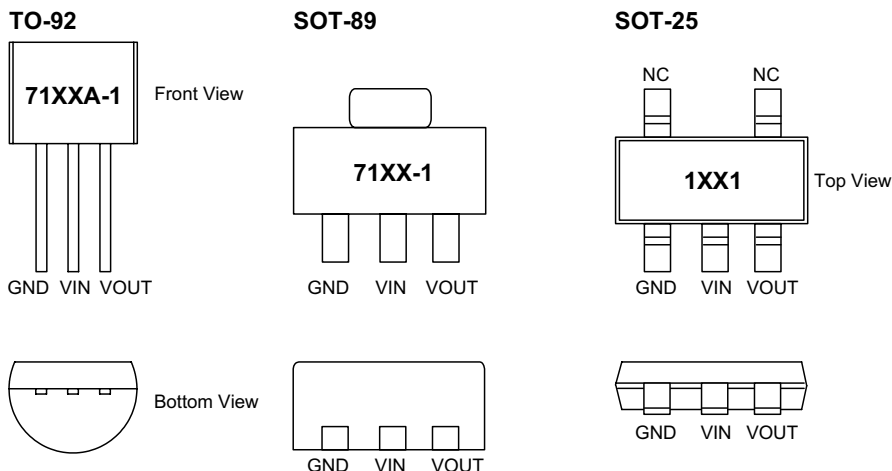

**Pad Assignment**

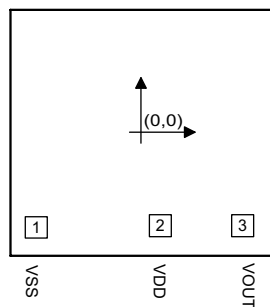

Chip size: 1111×1051 (μm)<sup>2</sup>

**Pad Coordinates**

Unit: μm

Pad No.	X	Y
1	-429.00	-401.00
2	123.50	-401.00
3	416.00	-401.00

\* The IC substrate should be connected to VDD in the PCB layout artwork.

**Absolute Maximum Ratings**

Supply Voltage .....	-0.3V to 26V	Storage Temperature .....	-50°C to 125°C
Power Consumption (*1) .....	200mW	Operating Temperature .....	0°C to 70°C
Power Consumption (*2) .....	150mW		

Note: These are stress ratings only. Stresses exceeding the range specified under "Absolute Maximum Ratings" may cause substantial damage to the device. Functional operation of this device at other conditions beyond those listed in the specification is not implied and prolonged exposure to extreme conditions may affect device reliability.

\*1: applied to SOT-89 and TO-92

\*2: applied to SOT-25

**Electrical Characteristics**
**HT7130-1, +3.0V output type**

Ta=25°C

Symbol	Parameter	Test Conditions		Min.	Typ.	Max.	Unit
		V <sub>IN</sub>	Conditions				
V <sub>OUT</sub>	Output Voltage	5V	I <sub>OUT</sub> =10mA	2.91	3	3.09	V
I <sub>OUT</sub>	Output Current	5V	—	20	30	—	mA
ΔV <sub>OUT</sub>	Load Regulation	5V	1mA ≤ I <sub>OUT</sub> ≤ 20mA	—	60	100	mV
V <sub>DIF</sub>	Voltage Drop	—	I <sub>OUT</sub> =1mA	—	100	—	mV
I <sub>SS</sub>	Current Consumption	5V	No load	—	3	6	μA
$\frac{\Delta V_{OUT}}{\Delta V_{IN} \times V_{OUT}}$	Line Regulation	—	4V ≤ V <sub>IN</sub> ≤ 24V I <sub>OUT</sub> =1mA	—	0.2	—	%/V
V <sub>IN</sub>	Input Voltage	—	—	—	—	24	V
$\frac{\Delta V_{OUT}}{\Delta T_a}$	Temperature Coefficient	5V	I <sub>OUT</sub> =10mA 0°C < Ta < 70°C	—	±0.45	—	mV/°C

**HT7133-1, +3.3V output type**

Ta=25°C

Symbol	Parameter	Test Conditions		Min.	Typ.	Max.	Unit
		V <sub>IN</sub>	Conditions				
V <sub>OUT</sub>	Output Voltage	5.5V	I <sub>OUT</sub> =10mA	3.201	3.3	3.399	V
I <sub>OUT</sub>	Output Current	5.5V	—	20	30	—	mA
ΔV <sub>OUT</sub>	Load Regulation	5.5V	1mA ≤ I <sub>OUT</sub> ≤ 30mA	—	60	100	mV
V <sub>DIF</sub>	Voltage Drop	—	I <sub>OUT</sub> =1mA	—	100	—	mV
I <sub>SS</sub>	Current Consumption	5.5V	No load	—	3	6	μA
$\frac{\Delta V_{OUT}}{\Delta V_{IN} \times V_{OUT}}$	Line Regulation	—	4.5V ≤ V <sub>IN</sub> ≤ 24V I <sub>OUT</sub> =1mA	—	0.2	—	%/V
V <sub>IN</sub>	Input Voltage	—	—	—	—	24	V
$\frac{\Delta V_{OUT}}{\Delta T_a}$	Temperature Coefficient	5.5V	I <sub>OUT</sub> =10mA 0°C < Ta < 70°C	—	±0.5	—	mV/°C

**HT7136-1, +3.6V output type**

Ta=25°C

Symbol	Parameter	Test Conditions		Min.	Typ.	Max.	Unit
		V <sub>IN</sub>	Conditions				
V <sub>OUT</sub>	Output Voltage	5.6V	I <sub>OUT</sub> =10mA	3.492	3.6	3.708	V
I <sub>OUT</sub>	Output Current	5.6V	—	20	30	—	mA
ΔV <sub>OUT</sub>	Load Regulation	5.6V	1mA ≤ I <sub>OUT</sub> ≤ 30mA	—	60	100	mV
V <sub>DIF</sub>	Voltage Drop	—	I <sub>OUT</sub> =1mA	—	60	—	mV
I <sub>SS</sub>	Current Consumption	5.6V	No load	—	3	6	μA
$\frac{\Delta V_{OUT}}{\Delta V_{IN} \times V_{OUT}}$	Line Regulation	—	4.6V ≤ V <sub>IN</sub> ≤ 24V I <sub>OUT</sub> =1mA	—	0.2	—	%/V
V <sub>IN</sub>	Input Voltage	—	—	—	—	24	V
$\frac{\Delta V_{OUT}}{\Delta T_a}$	Temperature Coefficient	5.6V	I <sub>OUT</sub> =10mA 0°C < Ta < 70°C	—	±0.6	—	mV/°C

**HT7144-1, +4.4V output type**

Ta=25°C

Symbol	Parameter	Test Conditions		Min.	Typ.	Max.	Unit
		V <sub>IN</sub>	Conditions				
V <sub>OUT</sub>	Output Voltage	6.4V	I <sub>OUT</sub> =10mA	4.268	4.4	4.532	V
I <sub>OUT</sub>	Output Current	6.4V	—	20	30	—	mA
ΔV <sub>OUT</sub>	Load Regulation	6.4V	1mA ≤ I <sub>OUT</sub> ≤ 30mA	—	60	100	mV
V <sub>DIF</sub>	Voltage Drop	—	I <sub>OUT</sub> =1mA	—	100	—	mV
I <sub>SS</sub>	Current Consumption	6.4V	No load	—	3	6	μA
$\frac{\Delta V_{OUT}}{\Delta V_{IN} \times V_{OUT}}$	Line Regulation	—	5.4V ≤ V <sub>IN</sub> ≤ 24V I <sub>OUT</sub> =1mA	—	0.2	—	%/V
V <sub>IN</sub>	Input Voltage	—	—	—	—	24	V
$\frac{\Delta V_{OUT}}{\Delta T_a}$	Temperature Coefficient	6.4V	I <sub>OUT</sub> =10mA 0°C < Ta < 70°C	—	±0.7	—	mV/°C

**HT7150-1, +5.0V output type**

Ta=25°C

Symbol	Parameter	Test Conditions		Min.	Typ.	Max.	Unit
		V <sub>IN</sub>	Conditions				
V <sub>OUT</sub>	Output Voltage	7V	I <sub>OUT</sub> =10mA	4.85	5	5.15	V
I <sub>OUT</sub>	Output Current	7V	—	20	30	—	mA
ΔV <sub>OUT</sub>	Load Regulation	7V	1mA ≤ I <sub>OUT</sub> ≤ 30mA	—	60	100	mV
V <sub>DIF</sub>	Voltage Drop	—	I <sub>OUT</sub> =1mA	—	100	—	mV
I <sub>SS</sub>	Current Consumption	7V	No load	—	3	6	μA
$\frac{\Delta V_{OUT}}{\Delta V_{IN} \times V_{OUT}}$	Line Regulation	—	6V ≤ V <sub>IN</sub> ≤ 24V I <sub>OUT</sub> =1mA	—	0.2	—	%/V
V <sub>IN</sub>	Input Voltage	—	—	—	—	24	V
$\frac{\Delta V_{OUT}}{\Delta T_a}$	Temperature Coefficient	7V	I <sub>OUT</sub> =10mA 0°C < Ta < 70°C	—	±0.75	—	mV/°C

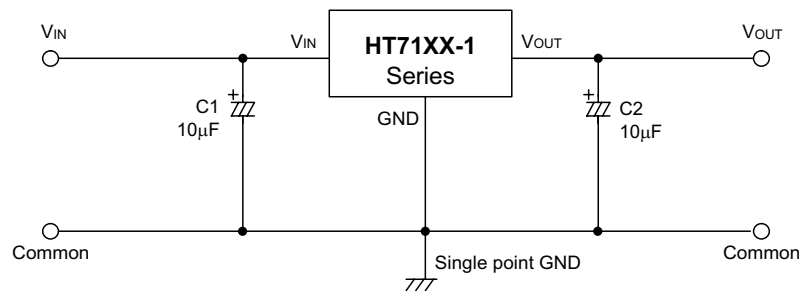
**Application Circuits**
**Basic circuits**

High output current positive voltage regulator

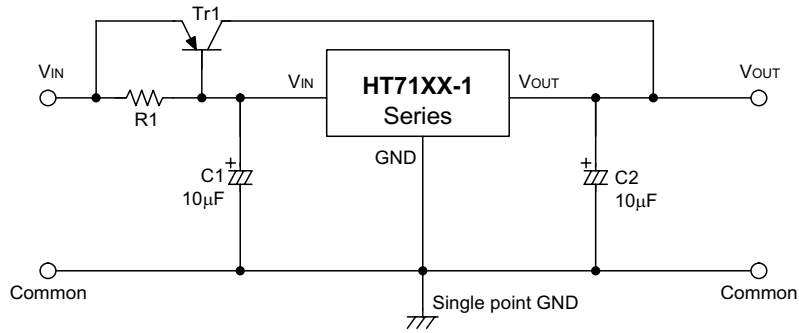

Short-Circuit protection by Tr1

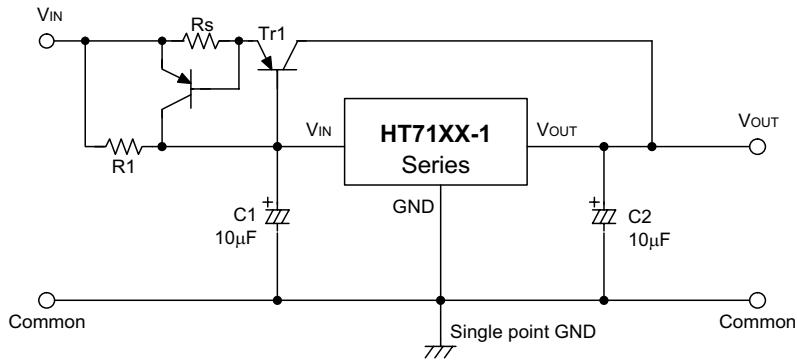

Circuit for increasing output voltage

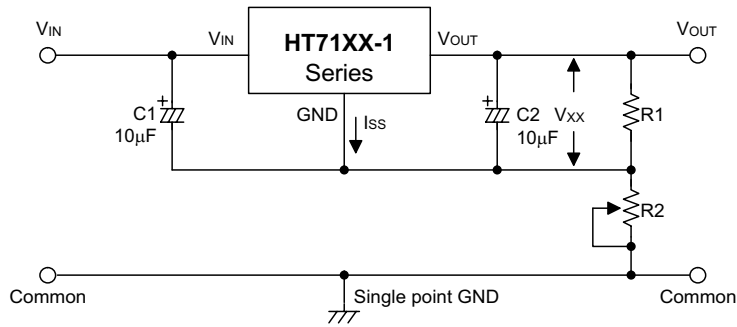

$$V_{OUT} = V_{xx} \left(1 + \frac{R2}{R1}\right) + I_{ss} R2$$

**Circuit for increasing output voltage**

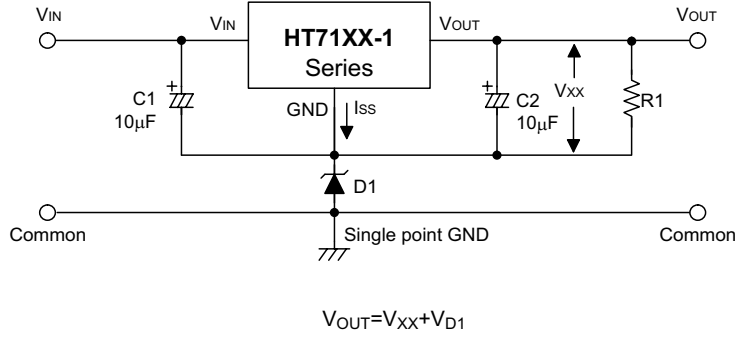

**Constant current regulator**

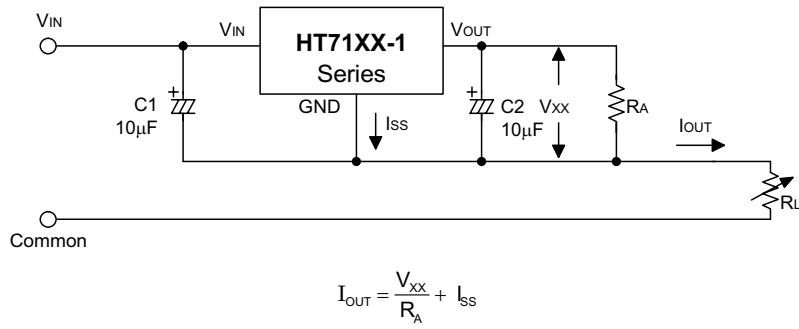

**Dual supply**

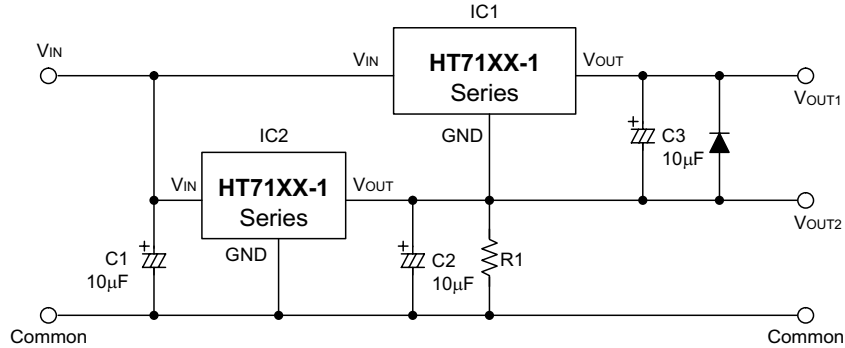

Package Information

3-pin TO-92 outline dimensions

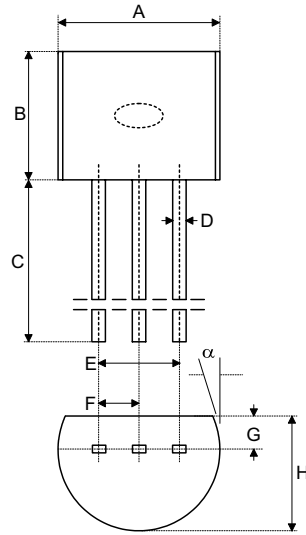

Symbol	Dimensions in mil		
	Min.	Nom.	Max.
A	170	—	200
B	170	—	200
C	500	—	—
D	11	—	20
E	90	—	110
F	45	—	55
G	45	—	65
H	130	—	160
I	8	—	18
$\alpha$	4°	—	6°

3-pin SOT-89 outline dimensions

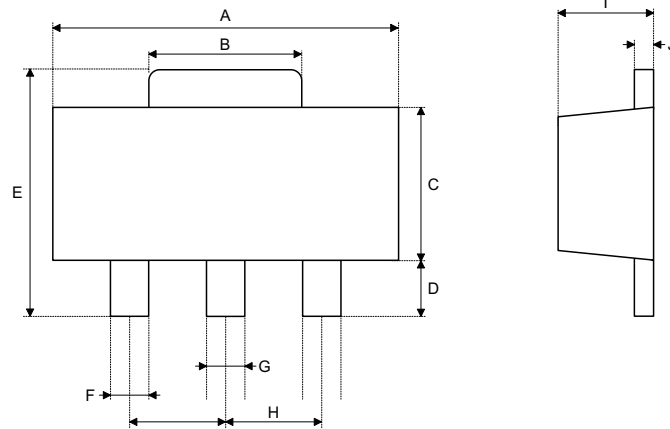

Symbol	Dimensions in mil		
	Min.	Nom.	Max.
A	173	—	181
B	64	—	72
C	90	—	102
D	35	—	47
E	155	—	167
F	14	—	19
G	17	—	22
H	—	59	—
I	55	—	63
J	14	—	17



5-pin SOT-25 outline dimensions

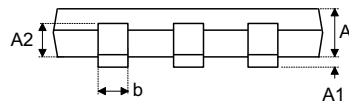
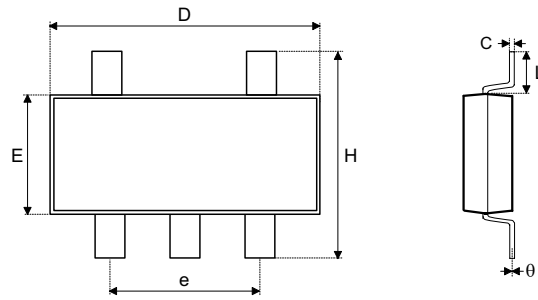

Symbol	Dimensions in mm		
	Min.	Nom.	Max.
A	1.00	—	1.30
A1	—	—	0.10
A2	0.70	—	0.90
b	0.35	—	0.50
C	0.10	—	0.25
D	2.70	—	3.10
E	1.40	—	1.80
e	—	1.90	—
H	2.60	—	3
L	0.37	—	—
θ	1°	—	9°

**Product Tape and Reel Specifications**

TO-92 reel dimensions (Unit: mm)

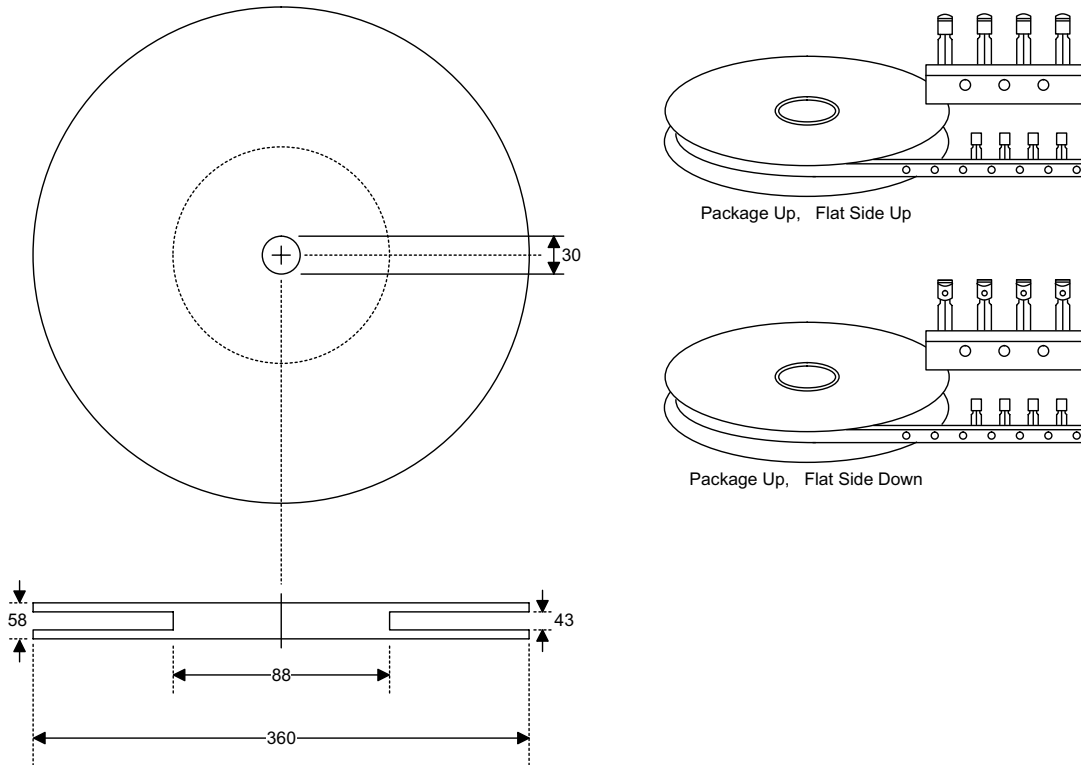

**SOT-89 & SOT-25 reel dimensions**

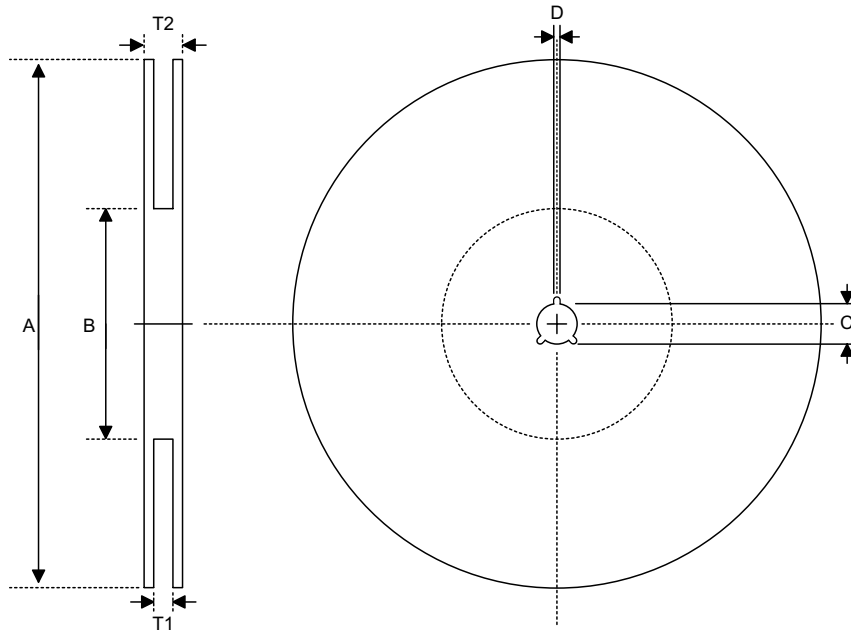

**SOT-89**

Symbol	Description	Dimensions in mm
A	Reel Outer Diameter	180±1.0
B	Reel Inner Diameter	62±1.5
C	Spindle Hole Diameter	12.75+0.15
D	Key Slit Width	1.9±0.15
T1	Space Between Flange	12.4+0.2
T2	Reel Thickness	17-0.4

**SOT-25**

Symbol	Description	Dimensions in mm
A	Reel Outer Diameter	178±1.0
B	Reel Inner Diameter	62±1.0
C	Spindle Hole Diameter	13.0±0.2
D	Key Slit Width	2.5±0.25
T1	Space Between Flange	8.4+1.5 -0.0
T2	Reel Thickness	11.4+1.5

**TO-92 carrier tape dimensions**

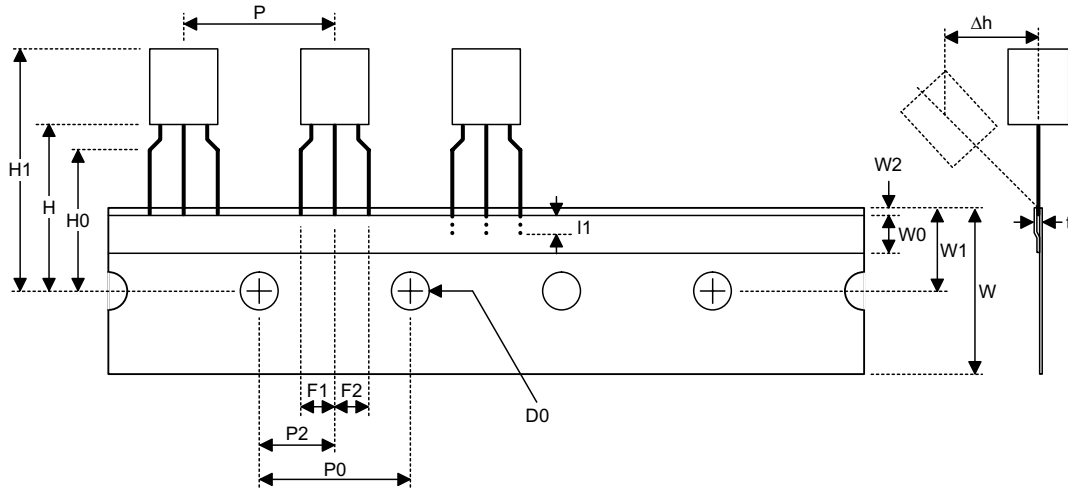

**TO-92**

Symbol	Description	Dimensions in mm
l1	Taped Lead Length	(2.5)
P	Component Pitch	12.7±1.0
P <sub>0</sub>	Perforation Pitch	12.7±0.3
P <sub>2</sub>	Component to Perforation (Length Direction)	6.35±0.4
F <sub>1</sub>	Lead Spread	2.5+0.4 -0.1
F <sub>2</sub>	Lead Spread	2.5+0.4 -0.1
Δh	Component Alignment	0±0.1
W	Carrier Tape Width	18.0+1.0 -0.5
W <sub>0</sub>	Hold-down Tape Width	6.0±0.5
W <sub>1</sub>	Perforation Position	9.0±0.5
W <sub>2</sub>	Hold-down Tape Position	(0.5)
H <sub>0</sub>	Lead Clinch Height	16.0±0.5
H <sub>1</sub>	Component Height	Less than 24.7
D <sub>0</sub>	Perforation Diameter	4.0±0.2
t	Taped Lead Thickness	0.7±0.2
H	Component Base Height	19.0±0.5

Note: Thickness less than 0.38±0.05mm~0.5mm

P<sub>0</sub> Accumulated pitch tolerance: ±1mm/20pitches.

( ) Bracketed figures are for consultation only

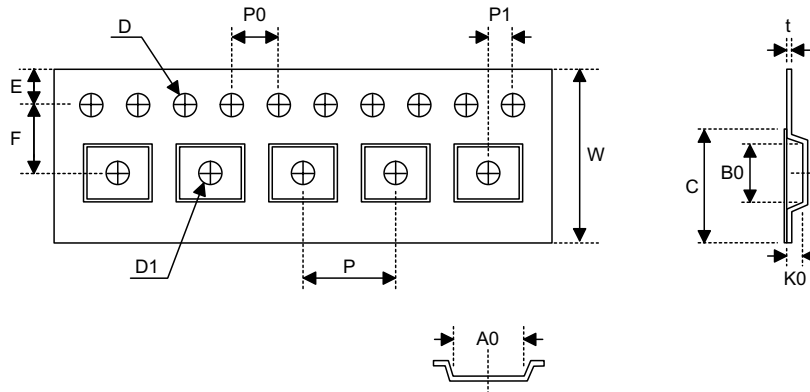
**SOT-89 & SOT-25 carrier tape dimensions**

**SOT-89**

Symbol	Description	Dimensions in mm
W	Carrier Tape Width	12.0+0.3 -0.1
P	Cavity Pitch	8.0±0.1
E	Perforation Position	1.75±0.1
F	Cavity to Perforation (Width Direction)	5.5±0.05
D	Perforation Diameter	1.5+0.1
D1	Cavity Hole Diameter	1.5+0.1
P0	Perforation Pitch	4.0±0.1
P1	Cavity to Perforation (Length Direction)	2.0±0.10
A0	Cavity Length	4.8±0.1
B0	Cavity Width	4.5±0.1
K0	Cavity Depth	1.8±0.1
t	Carrier Tape Thickness	0.30±0.013
C	Cover Tape Width	9.3

**SOT-25**

Symbol	Description	Dimensions in mm
W	Carrier Tape Width	8.0+0.3 -0.3
P	Cavity Pitch	4.0
E	Perforation Position	1.75
F	Cavity to Perforation (Width Direction)	3.5±0.05
D	Perforation Diameter	1.5+0.1
D1	Cavity Hole Diameter	1.5+0.1
P0	Perforation Pitch	4.0
P1	Cavity to Perforation (Length Direction)	2.0
A0	Cavity Length	3.15
B0	Cavity Width	3.2
K0	Cavity Depth	1.4
t	Carrier Tape Thickness	0.20±0.03
C	Cover Tape Width	

**Holtek Semiconductor Inc. (Headquarters)**

No.3, Creation Rd. II, Science-based Industrial Park, Hsinchu, Taiwan  
Tel: 886-3-563-1999  
Fax: 886-3-563-1189  
<http://www.holtek.com.tw>

**Holtek Semiconductor Inc. (Sales Office)**

11F, No.576, Sec.7 Chung Hsiao E. Rd., Taipei, Taiwan  
Tel: 886-2-2782-9635  
Fax: 886-2-2782-9636  
Fax: 886-2-2782-7128 (International sales hotline)

**Holtek Semiconductor (Shanghai) Inc.**

7th Floor, Building 2, No.889, Yi Shan Rd., Shanghai, China  
Tel: 021-6485-5560  
Fax: 021-6485-0313  
<http://www.holtek.com.cn>

**Holtek Semiconductor (Hong Kong) Ltd.**

RM.711, Tower 2, Cheung Sha Wan Plaza, 833 Cheung Sha Wan Rd., Kowloon, Hong Kong  
Tel: 852-2-745-8288  
Fax: 852-2-742-8657

**Holmate Semiconductor, Inc.**

46712 Fremont Blvd., Fremont, CA 94538  
Tel: 510-252-9880  
Fax: 510-252-9885  
<http://www.holmate.com>

Copyright © 2002 by HOLTEK SEMICONDUCTOR INC.

The information appearing in this Data Sheet is believed to be accurate at the time of publication. However, Holtek assumes no responsibility arising from the use of the specifications described. The applications mentioned herein are used solely for the purpose of illustration and Holtek makes no warranty or representation that such applications will be suitable without further modification, nor recommends the use of its products for application that may present a risk to human life due to malfunction or otherwise. Holtek's products are not authorized for use as critical components in life support devices or systems. Holtek reserves the right to alter its products without prior notification. For the most up-to-date information, please visit our web site at <http://www.holtek.com.tw>.