

**Features**

- Operating voltage: 3V~5V
- Low power consumption and high noise immunity CMOS technology
- Built-in oscillator needs only 5% resistor
- $3^{12}$  trinary address codes
- 6 decoder control data outputs
- 3 local alarm trigger inputs:
  - TRIG, AL+, AL-
- Valid transmission indicator (LED)
- ACC disarms the whole car alarm system
- Easy interface with RF or IR medium

**General Description**

The HT6280 is an 18-bit decoder CMOS LSI designed for use in remote control car alarm system. When complemented by one of the TE triggered HT600/HT640/HT680 or DATA triggered HT6187/HT6207/HT6247 encoder ICs from a range of  $3^{18}$  series of encoders, a complete remote car alarm system can be formed. The details on the  $3^{18}$  encoders can be found in the relevant databook encoder section.

After receiving the 18 bits of information from the encoder the HT6280 interprets the first 12 bits as address and the last 6 bits as control signal data. If these received 12 bits of address matches that of the locally set address then the 6 data bits are latched and the control function executed. Three types of control function are incorporated in the device, these are arm/disarm, panic and power on/off. The HT6280 also provides 3 momentary data outputs for other user defined special purposes.

**Pin Assignment**

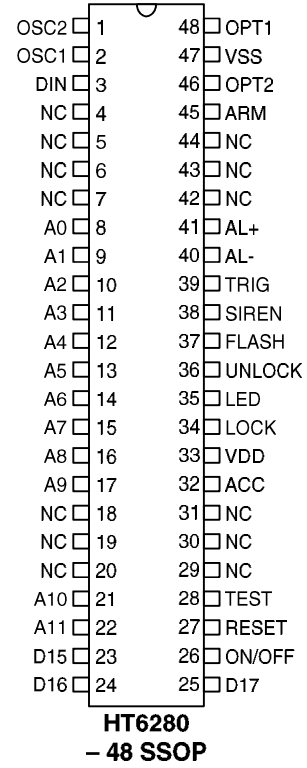
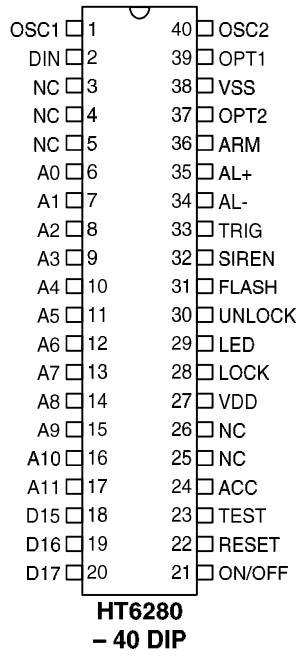
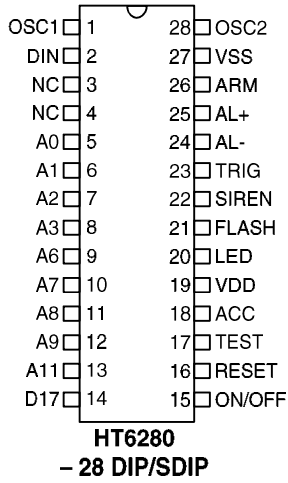

**Block Diagram**

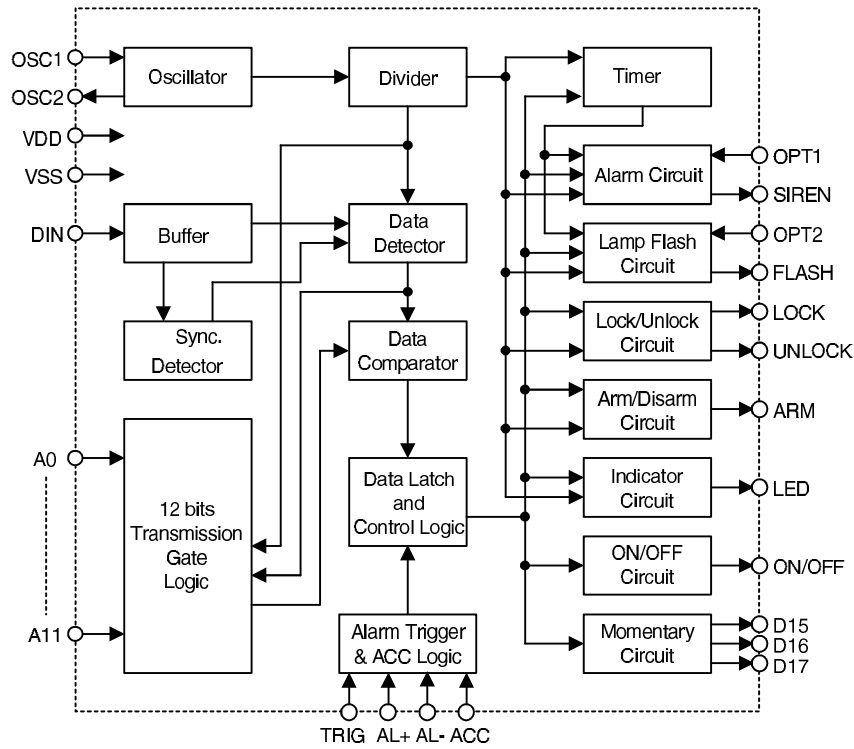

**Pin Description**

**HT6280 — 40 Pins**

Pin No.	Pin Name	I/O	Internal Connection	Description
1	OSC2	I	OSCILLATOR	Oscillator output pin
2	DIN	I	CMOS IN	Serial data input pin
3~5	NC	—	—	No connection
6~17	A0~A11	I	TRANSMISSION GATE	A0~A11 address inputs They can be set to VDD, VSS, or floating.
18~20	D15~D17	O	CMOS OUT	D15~D17 momentary data outputs from D15~D17 of an encoder, for external control use
21	ON/OFF	O	CMOS OUT	ON/OFF output pin for external control use Toggle outputs of the ON/OFF pin are triggered by D14 of an encoder

<b>Pin No.</b>	<b>Pin Name</b>	<b>I/O</b>	<b>Internal Connection</b>	<b>Description</b>
22	RESET	I	CMOS IN	System reset pin
23	TEST	O	CMOS OUT	For IC testing only
24	ACC	I	CMOS IN Pull-Low	An active high signal to the ACC pin disarms the alarm system
25,26	NC	—	—	No connection
27	VDD	I	—	Positive power supply
28	LOCK	O	CMOS OUT	Lock signal output to control external lock/unlock, active high
29	LED	O	NMOS OUT	LED indicator for arm/disarm, alarm, and panic
30	UNLOCK	O	CMOS OUT	Unlock signal output to control external lock/unlock, active high
31	FLASH	O	CMOS OUT	Flash output pin to control external car lamp circuit, active high
32	SIREN	O	CMOS OUT	Alarm output pin to control external siren circuit, active high
33	TRIG	I	CMOS IN Pull-High	Alarm trigger input in the arm state, active high
34	AL-	I	CMOS IN Pull-High	Alarm trigger input in the arm state, active low
35	AL+	I	CMOS IN Pull-Low	Alarm trigger input in the arm state, active high
36	ARM	O	CMOS OUT	Arm state output, active high This pin is toggled by D12 of an encoder
37	OPT2	I	CMOS IN Pull-High	Car lamp flash selection during alarm: VSS: Lamp flash VDD or Open: Lamp flash disabled
38	VSS	I	—	Negative power supply (GND)
39	OPT1	I	CMOS IN Pull-High	Chirp sound selection during change of arm/disarm states: VSS: Chirp VDD or Open: Chirp disabled
40	OSC1	I	OSCILLATOR	Oscillator input pin

**Approximate internal connection circuits**

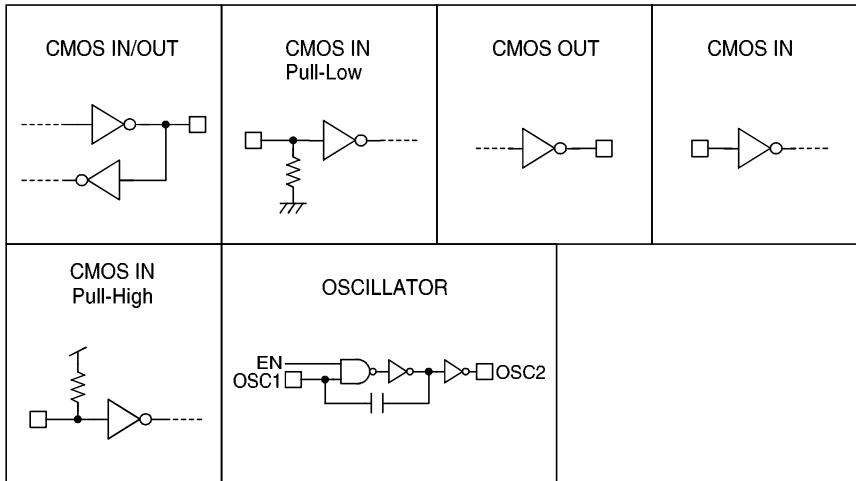

**Absolute Maximum Ratings\***

Supply Voltage ..... -0.3V to 5.5V      Storage Temperature..... -50°C to 125°C  
 Input Voltage..... V<sub>SS</sub>-0.3 to V<sub>DD</sub>+0.3V      Operating Temperature..... -20°C to 75°C

\*Note: Stresses above those listed under “Absolute Maximum Ratings” may cause permanent damage to the device. These are stress ratings only. Functional operation of this device at these or any other conditions above those indicated in the operational sections of this specification is not implied and exposure to absolute maximum rating conditions for extended periods may affect device reliability.

**Electrical Characteristics**

(Ta=25°C)

Symbol	Parameter	Test Conditions		Min.	Typ.	Max.	Unit
		V <sub>DD</sub>	Conditions				
V <sub>DD</sub>	Supply Voltage	—	—	3	—	5	V
I <sub>STB</sub>	Standby Current	5V	Oscillator stops	—	2	4	μA
I <sub>DD</sub>	Operating Current	5V	No load F <sub>OSC</sub> =100kHz	—	200	400	μA
R <sub>PH</sub>	Pull-High Resistance	5V	V <sub>IN</sub> =0V	—	150	—	kΩ
R <sub>PL</sub>	Pull-Low Resistance	5V	V <sub>IN</sub> =5V	—	150	—	kΩ
I <sub>OUT1</sub>	Output Current (D15~D17)	Source	5V V <sub>OUT</sub> =0.9V <sub>DD</sub>	-0.3	-0.6	—	mA
		Sink	5V V <sub>OUT</sub> =0.1V <sub>DD</sub>	0.5	1	—	mA
I <sub>OUT2</sub>	Output Current (ON/OFF)	Source	5V V <sub>OUT</sub> =0.9V <sub>DD</sub>	-0.7	-1.2	—	mA
		Sink	5V V <sub>OUT</sub> =0.1V <sub>DD</sub>	0.5	1	—	mA

Symbol	Parameter	Test Conditions		Min.	Typ.	Max.	Unit	
		V <sub>DD</sub>	Conditions					
I <sub>OUT3</sub>	Output Current (LOCK, UNLOCK)	Source	5V	V <sub>OUT</sub> =0.9V <sub>DD</sub>	-2	-4	—	mA
		Sink	5V	V <sub>OUT</sub> =0.1V <sub>DD</sub>	0.5	1	—	mA
I <sub>OUT4</sub>	Output Current (FLASH, SIREN)	Source	5V	V <sub>OUT</sub> =0.9V <sub>DD</sub>	-1.5	-3	—	mA
		Sink	5V	V <sub>OUT</sub> =0.1V <sub>DD</sub>	0.5	1	—	mA
I <sub>OUT5</sub>	Output Current (ARM)	Source	5V	V <sub>OUT</sub> =0.9V <sub>DD</sub>	-1	-2	—	mA
		Sink	5V	V <sub>OUT</sub> =0.1V <sub>DD</sub>	0.5	1	—	mA
I <sub>LED</sub>	Output Current	Sink	5V	V <sub>OUT</sub> =0.1V <sub>DD</sub>	1	2	—	mA
V <sub>IH</sub>	“H” Input Voltage	—	—	0.8V <sub>DD</sub>	—	V <sub>DD</sub>	V	
V <sub>IL</sub>	“L” Input Voltage	—	—	0	—	0.2V <sub>DD</sub>	V	
F <sub>OSC</sub>	System Frequency	5V	R <sub>OSC</sub> =200kΩ	—	100	—	kHz	

## Functional Description

### Operation

After the power is on, the HT6280 receives a data word from one of the 3<sup>18</sup> series of encoders. It interprets the first 12 bits of code as address and the last 6 bits as data. The decoder then compares the received address with its local address code twice successively. If the received address code match the local address code, the 6 data bits are decoded to the output pins.

### Power on initial

The HT6280 is in the arm state at the initial power on.

### Arm/disarm control

The ARM signal toggles the arm/disarm condition of the HT6280. If the decoder is in the arm state and a signal has been received on the ARM pin (the D12 signal of an encoder) the car lights flash twice continuously, the chirp sounds twice successively and the alarm system enters the disarm state. Similarly, if the arm/disarm signal is received again the lights also flash once, the chirp sounds once, and the alarm system enters the arm state. The timing of arm/disarm is shown below.

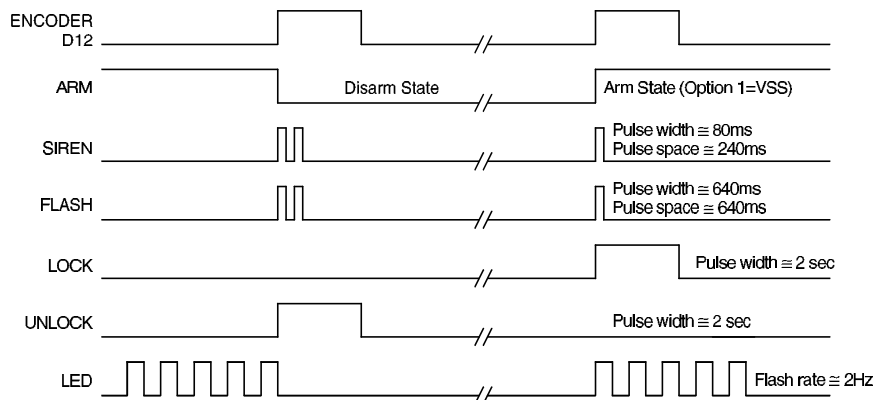

Fig.1 No panic/alarm trigger for the arm state

**Alarm triggering (AL+, AL-, TRIG)**

With the alarm in the arm state, any one of the three signals AL+, AL-, and TRIG can trigger the alarm. Triggering the alarm causes the lights to flash at a 2Hz rate (OPT2=VSS) and the siren to sound. If the trigger is removed within 4 cycles, the flashing lights and the siren cease at the end of that cycle; otherwise they go on to complete new 4 cycles. A cycle lasts for 30

seconds on and 10 seconds off. During an alarm trigger the LED flashes at an 8Hz rate and then continues even if the trigger is removed. Activating the ACC (the alarm reset line) will turn the LED off in addition to the lights and the siren. If the AL+, AL- and TRIG lines are disabled in the disarm state, the panic function is still enabled. The timing of the alarm trigger is shown below.

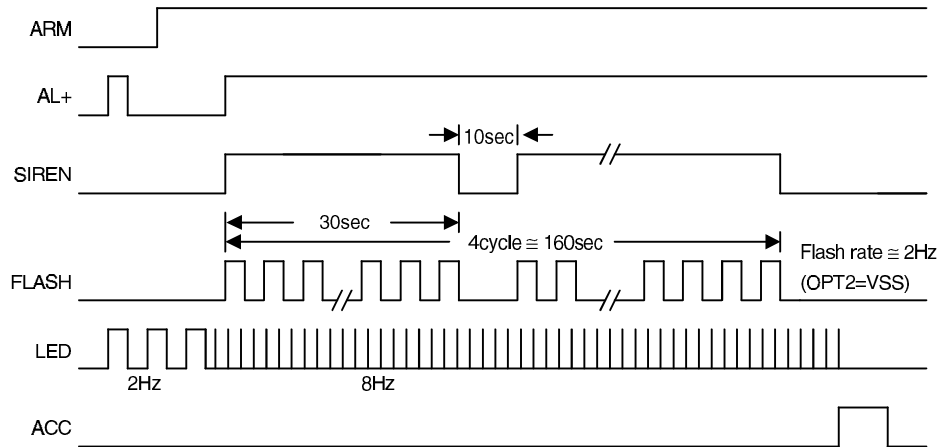

Fig.2 Alarm trigger (AL+, AL-, TRIG) for the arm state

**Panic control**

If a panic signal (D13) has been received whether in the arm or disarm state, the siren sounds and the flash of car lights lasts for one

cycle until the ACC pin is activated. The LED will flash quickly and then turn off if ACC is activated whether the siren is in the working or stop state. The timing is shown below.

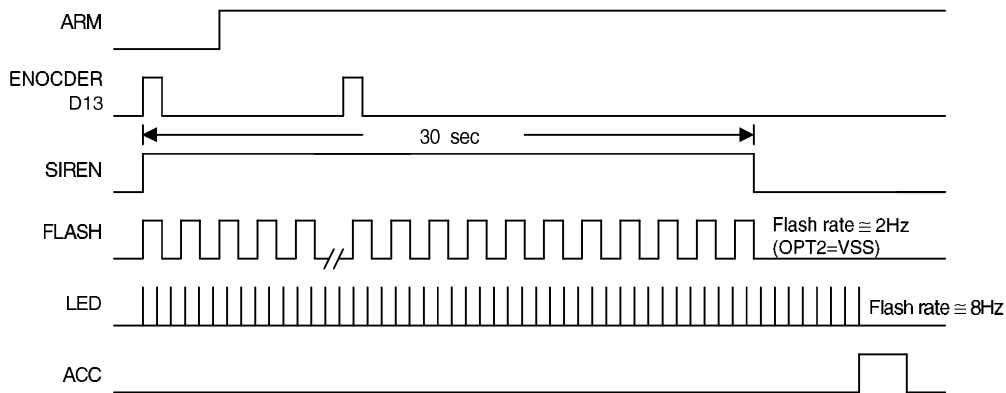

Fig.3 Panic trigger for the arm state

**Alarm output (SIREN)**

If a trigger (AL+, AL-, or TRIG) has been removed within a period of 4 cycles, the SIREN will stop at that cycle. Otherwise it will continue to complete another period of 4 cycles. The timing of a cycle is about 30 seconds on and 10 seconds off. The alarm state is quitted by the arm/disarm (D12) trigger.

If the panic turns on (active high) whether in the arm or disarm state, the SIREN will output one cycle (30 seconds on and 10 seconds off). The alarm state is ferminated by an active high ACC signal.

The SIREN outputs an 80ms pulse when the HT6280 enters the arm state. It then outputs two pulses (Pulse width=80ms Pulse space=240ms) when the decoder enters the disarm state by the arm/disarm (D12) trigger. This function can be inhibited by floating OPT1.

**LOCK/UNLOCK output**

The LOCK and UNLOCK pins are not activated at the initial power on. The LOCK pin outputs a 2-second pulse when the HT6280 enters the arm state. The UNLOCK pin, on the other hand, outputs a 2-second pulse when the decoder enters the disarm state. The LOCK and UNLOCK pins cannot operate simultaneously but LOCK takes priority over UNLOCK. The timing is shown in Fig.1.

**FLASH output**

The FLASH pin outputs a pulse when the HT6280 enters the arm state or two pulses when the decoder enters the disarm state. After the siren operates, the light will flash at a 2Hz rate until the siren ceases. This function can be inhibited by floating OPT2.

**LED output**

The LED pin is of high impedance at the initial power on. In the arm state the LED flashes at a 2Hz rate. But if the alarm or panic is triggered the LED flashes at an 8Hz rate until the ACC pin is activated. The timing is shown in Fig.1.

**Encoder/Decoder reference table**

Encoder Data	Decoder Function
D12	Arm/Disarm toggle
D13	Panic control
D14	ON/OFF toggle
D15	Momentary data output D15
D16	Momentary data output D16
D17	Momentary data output D17

**ACC input**

After the active high ACC input is activated, the car alarm system enters the disarm state, the arm/disarm (D12), panic, or other control signals fail to be received, and the LED stops flashing.

**ARM output**

The ARM outputs a “Hi” signal when the HT6280 is operating in the arm state. Otherwise it outputs a “Lo” signal.

**ON/OFF output**

The ON/OFF pin provides an external toggle on/off control when the HT6280 responds to the D14 signal from the encoder. The ON/OFF timing is shown below.

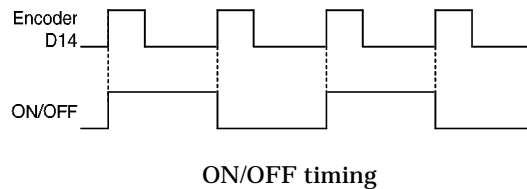

**D15–D17 data output**

D15–D17 of the HT6280 are momentary type data outputs which follow D15–D17 of an encoder. These lines are for user-defined control use. The timing is shown next.



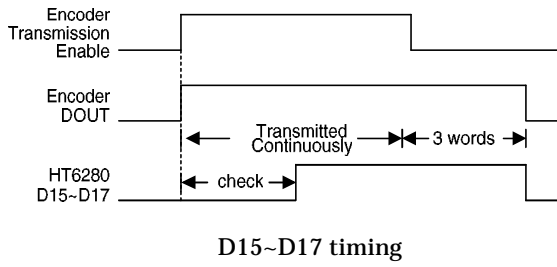

Flowchart

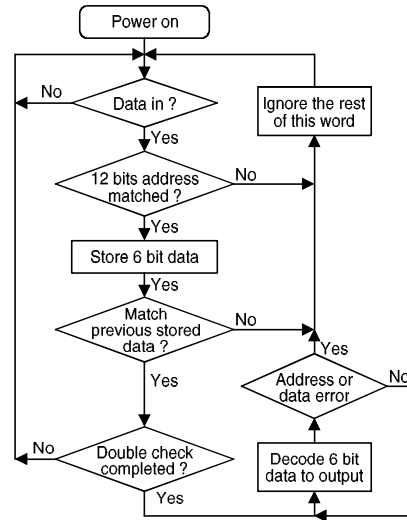

Oscillator frequency vs supply voltage

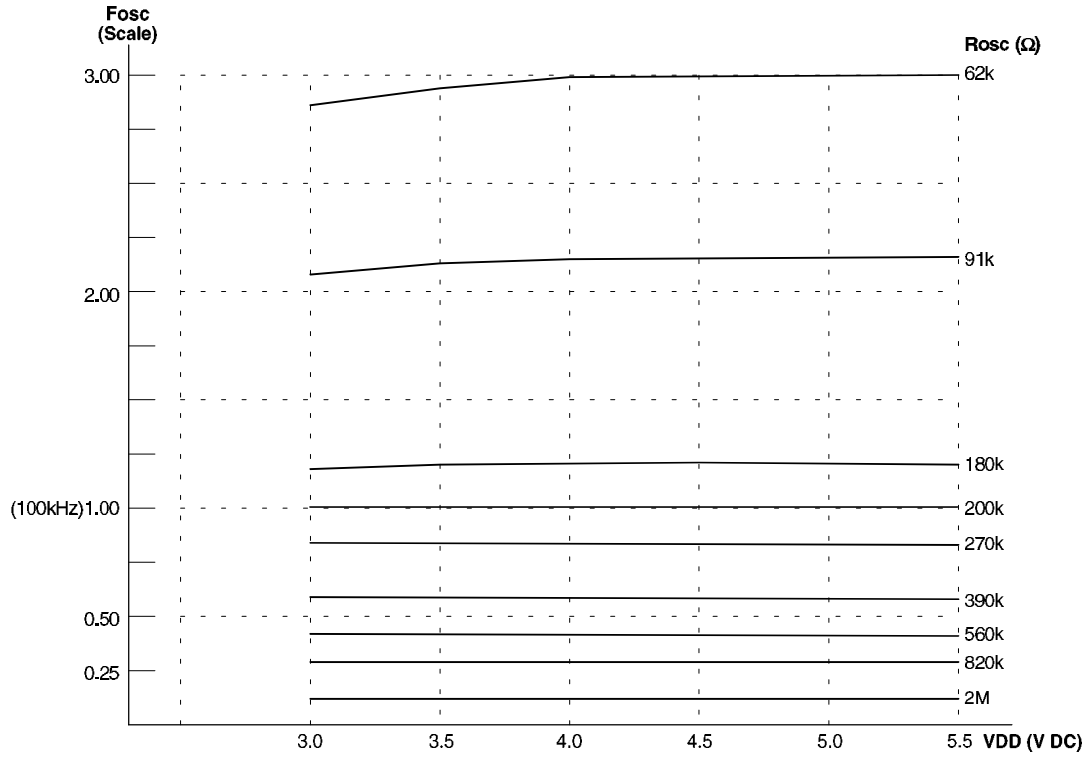

The recommended oscillator frequency is  $F_{OSCD}$  (decoder)  $\cong$   $F_{OSCE}$  (encoder).

**Application Circuits**

40-pin DIP package

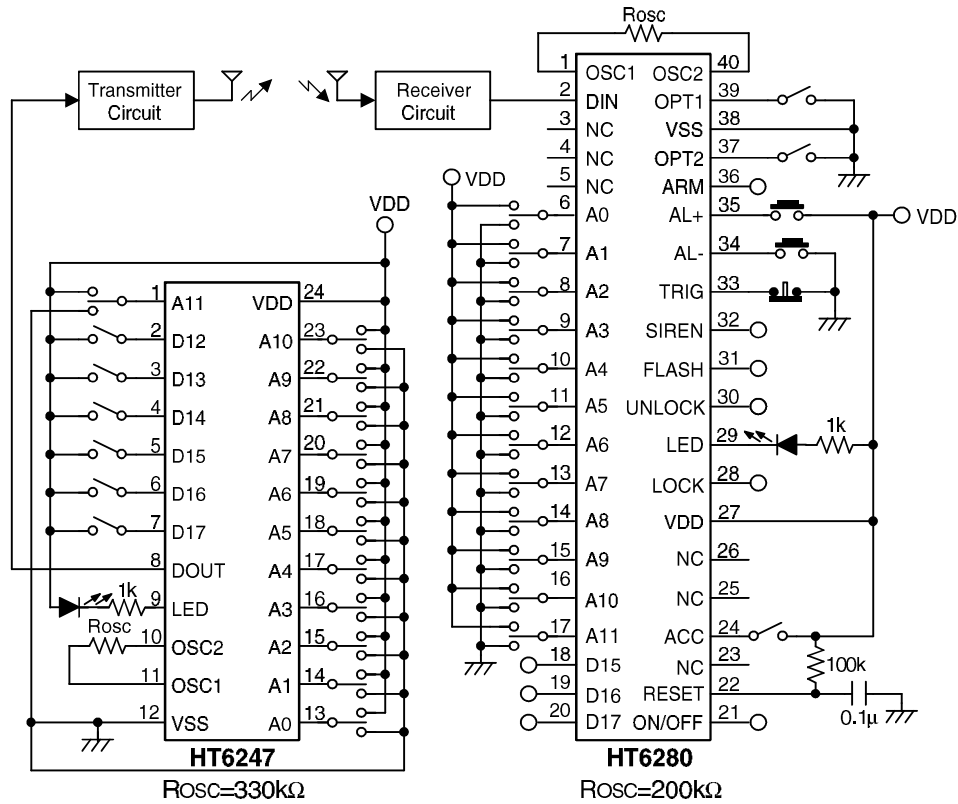

Note: Typical infrared diode: EL-1L2 (KODENSHI CORP.)  
 Typical RF transmitter: JR-220 (JUWA CORP.)  
 Typical infrared receiver: PIC-12043T/PIC-12043S (KODESHI CORP.)  
 or LTM9052 (LITEON CORP.)  
 Typical RF receiver: JR-200 (JUWA CORP.)