

## Features

- Operating voltage: 2.4V~12V
- Low power and high noise immunity CMOS technology
- Low standby current
- Capable of decoding 12 bits of information
- Pair with HOLTEK's 2<sup>12</sup> series of encoders
- Binary address setting
- Received codes are checked 3 times
- Address/Data number combination:
  - HT12D: 8 address bits and 4 data bits
  - HT12F: 12 address bits only
- Built-in oscillator needs only 5% resistor
- Valid transmission indicator
- Easy interface with an RF or an infrared transmission medium
- Minimal external components

## Applications

- Burglar alarm system
- Smoke and fire alarm system
- Garage door controllers
- Car door controllers
- Car alarm system
- Security system
- Cordless telephones
- Other remote control systems

## General Description

The 2<sup>12</sup> decoders are a series of CMOS LSIs for remote control system applications. They are paired with HOLTEK's 2<sup>12</sup> series of encoders (refer to the encoder/decoder cross reference table). For proper operation, a pair of encoder/decoder with the same number of addresses and data format should be chosen.

The decoders receive serial addresses and data from a programmed 2<sup>12</sup> series of encoders that are transmitted by a carrier using an RF or an IR transmission medium. They compare the serial input data three times continuously with

their local addresses. If no error or unmatched codes are found, the input data codes are decoded and then transferred to the output pins. The VT pin also goes high to indicate a valid transmission.

The 2<sup>12</sup> series of decoders are capable of decoding informations that consist of N bits of address and 12-N bits of data. Of this series, the HT12D is arranged to provide 8 address bits and 4 data bits, and HT12F is used to decode 12 bits of address information.

## Selection Table

Function Item	Address No.	Data		VT	Oscillator	Trigger	Package
		No.	Type				
HT12D	8	4	L	√	RC oscillator	DIN active "Hi"	18 DIP/20 SOP
HT12F	12	0	—	√	RC oscillator	DIN active "Hi"	18 DIP/20 SOP

Note: Data type: M represents the momentary type of data output.  
L represents the latch type of data output.

VT can be used as a momentary data output.

**Block Diagram**

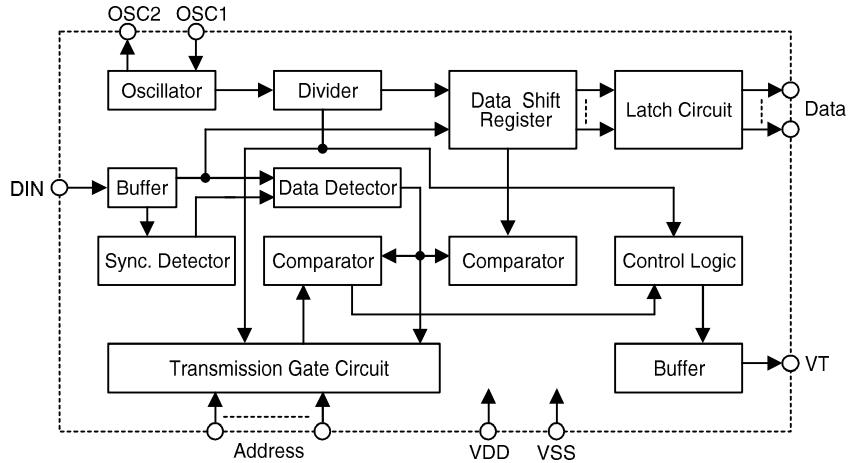

Note: The address/data pins are available in various combinations (see the address/data table).

**Pin Description**

Pin Name	I/O	Internal Connection	Description
A0~A11	I	NMOS TRANSMISSION GATE	Input pins for address A0~A11 setting They can be externally set to VDD or VSS.
D8~D11	O	CMOS OUT	Output data pins
DIN	I	CMOS IN	Serial data input pin
VT	O	CMOS OUT	Valid transmission, active high
OSC1	I	OSCILLATOR	Oscillator input pin
OSC2	O	OSCILLATOR	Oscillator output pin
VSS	I	—	Negative power supply (GND)
VDD	I	—	Positive power supply

**Approximate internal connection circuits**

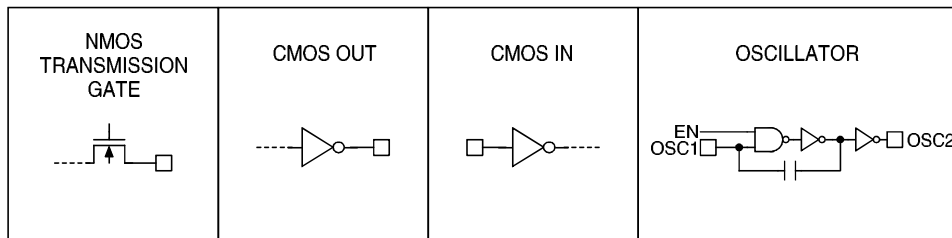

**Absolute Maximum Ratings\***

Supply Voltage ..... -0.3V to 13V      Storage Temperature..... -50°C to 125°C  
 Input Voltage.....  $V_{SS}-0.3$  to  $V_{DD}+0.3V$       Operating Temperature..... -20°C to 75°C

\*Note: Stresses above those listed under “Absolute Maximum Ratings” may cause permanent damage to the device. These are stress ratings only. Functional operation of this device at these or any other conditions above those indicated in the operational sections of this specification is not implied and exposure to absolute maximum rating conditions for extended periods may affect device reliability.

**Electrical Characteristics**

(Ta=25°C)

Symbol	Parameter	Test Conditions		Min.	Typ.	Max.	Unit
		V <sub>DD</sub>	Conditions				
V <sub>DD</sub>	Operating Voltage	—	—	2.4	5	12	V
I <sub>STB</sub>	Standby Current	5V	Oscillator stops	—	0.1	1	μA
		12V		—	2	4	μA
I <sub>DD</sub>	Operating Current	5V	No load F <sub>OSC</sub> =150kHz	—	200	400	μA
I <sub>O</sub>	Data Output Source Current (D8~D11)	5V	V <sub>OH</sub> =4.5V	-1	-1.6	—	mA
	Data Output Sink Current (D8~D11)	5V	V <sub>OL</sub> =0.5V	1	1.6	—	mA
I <sub>VT</sub>	VT Output Source Current	5V	V <sub>OH</sub> =4.5V	-1	-1.6	—	mA
	VT Output Sink Current		V <sub>OL</sub> =0.5V	1	1.6	—	mA
V <sub>IH</sub>	“H” Input Voltage	5V	—	3.5	—	5	V
V <sub>IL</sub>	“L” Input Voltage	5V	—	0	—	1	V
F <sub>OSC</sub>	Oscillator Frequency	5V	R <sub>OSC</sub> =51kΩ	—	150	—	kHz

**Functional Description**

**Operation**

The 2<sup>12</sup> series of decoders provides various combinations of addresses and data pins in different packages so as to pair with the 2<sup>12</sup> series of encoders.

The decoders receive data that are transmitted by an encoder and interpret the first N bits of code period as addresses and the last 12-N bits as data, where N is the address code number. A signal on the DIN pin activates the oscillator which in turn decodes the incoming address and data. The decoders will then check the received address three times continuously. If the received address codes all match the contents of the decoder's local address, the 12-N bits of data are decoded to activate the output pins and the VT pin is set high to indicate a valid transmission. This will last unless the address code is incorrect or no signal is received.

The output of the VT pin is high only when the transmission is valid. Otherwise it is always low.

**Output type**

Of the 2<sup>12</sup> series of decoders, the HT12F has no data output pin but its VT pin can be used as a momentary data output. The HT12D, on the other hand, provides 4 latch type data pins whose data remain unchanged until new data are received.

Part No.	Data Pins	Address Pins	Output Type	Operating Voltage
HT12D	4	8	Latch	2.4V~12V
HT12F	0	12	—	2.4V~12V

**Flowchart**

The oscillator is disabled in the standby state and activated when a logic "high" signal applies to the DIN pin. That is to say, the DIN should be kept low if there is no signal input.

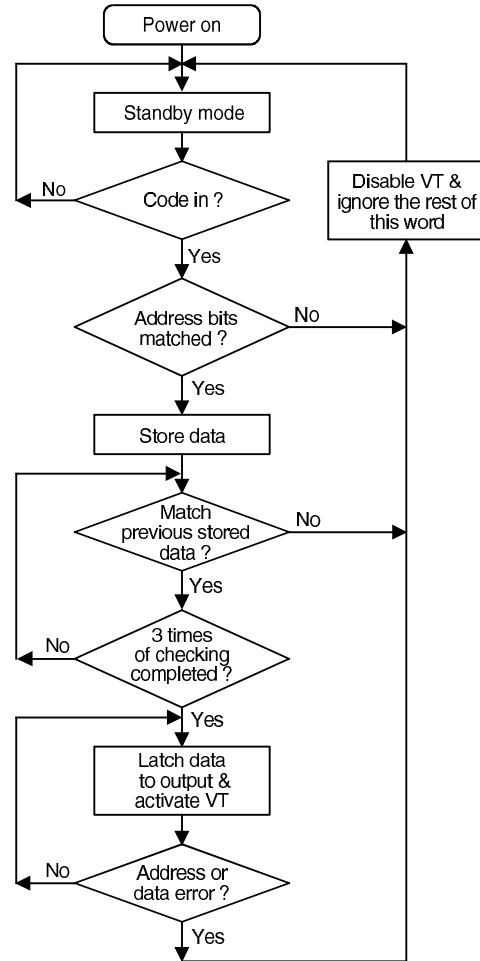

**Decoder timing**

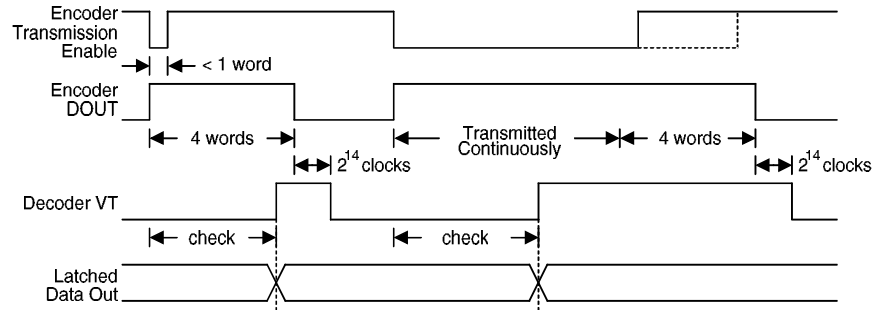

**Encoder/Decoder cross reference table**

Decoders Part No.	Data Pins	Address Pins	VT	Pair Encoder	Package			
					Encoder		Decoder	
					DIP	SOP	DIP	SOP
HT12D	4	8	√	HT12A/B	18	20	18	20
				HT12E	18	20		
HT12F	0	12	√	HT12A/B	18	20	18	20
				HT12E	18	20		

**Address/Data sequence**

The following table provides address/data sequence for various models of the 2<sup>12</sup> series of decoders. A correct device should be chosen according to the requirements of individual addresses and data.

Part No.	Address/Data Bits											
	0	1	2	3	4	5	6	7	8	9	10	11
HT12D	A0	A1	A2	A3	A4	A5	A6	A7	D8	D9	D10	D11
HT12F	A0	A1	A2	A3	A4	A5	A6	A7	A8	A9	A10	A11

Oscillator frequency vs supply voltage

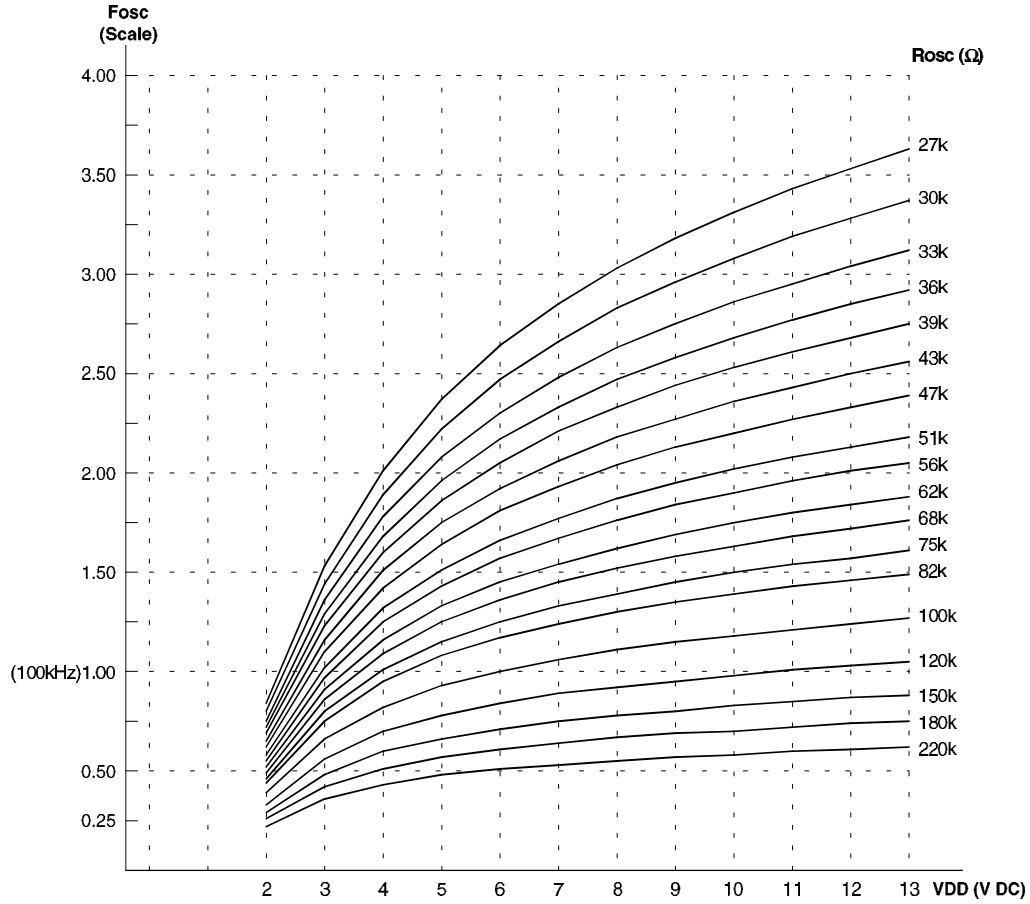

The recommended oscillator frequency is  $F_{OSCD}(\text{decoder}) \cong 50 F_{OSCE}(\text{HT12E encoder})$   
 $\cong \frac{1}{3} F_{OSCE}(\text{HT12A/B/C encoder})$ .

**Package Information**

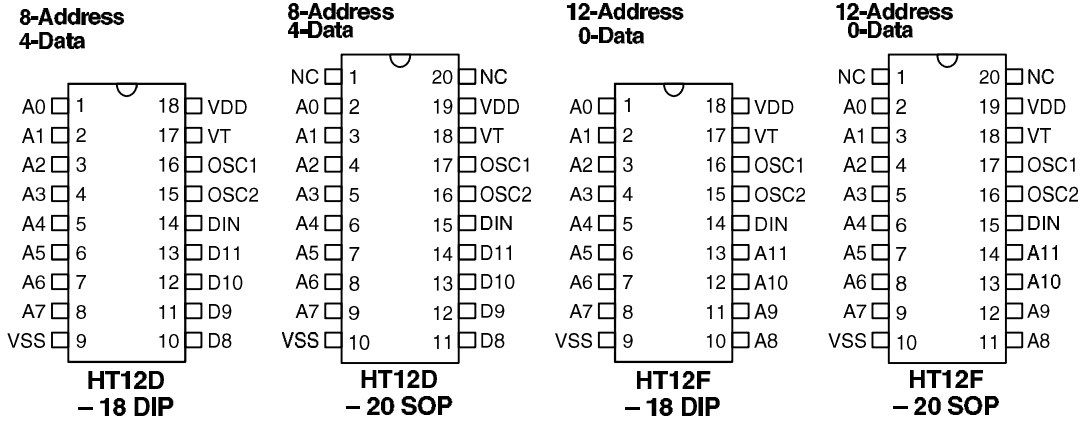

**Application Circuits**

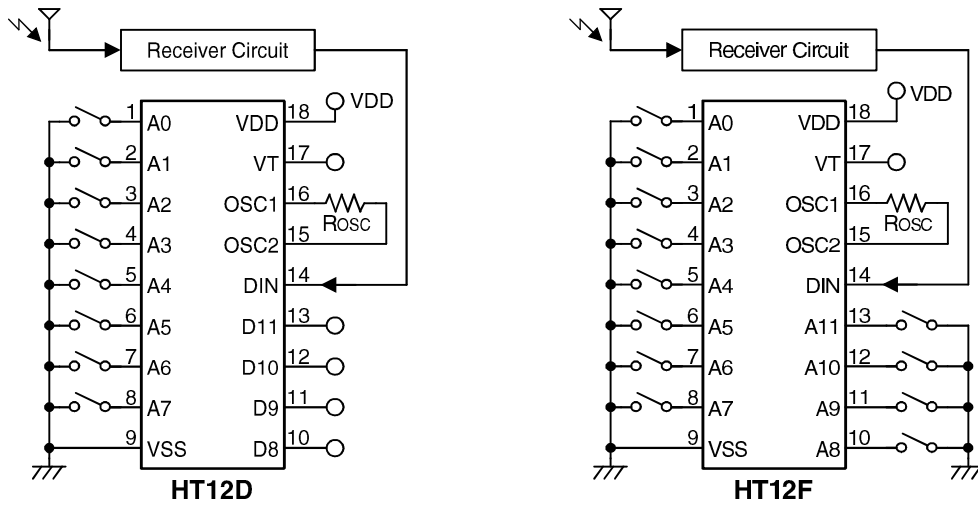

Note: Typical infrared receiver: PIC-12043T/PIC-12043S (KODESHI CORP.)  
or LTM9052 (LITEON CORP.)

Typical RF receiver: JR-200 (JUWA CORP.)  
RE-99 (MING MICROSYSTEM, U.S.A.)